

BIOLOGY EXAM

Date : Example

Time : 13:30 to 16:30

Number of questions : 35 of which
16 multiple-choice and
19 open questions

Write your name on every sheet you hand in.
The questions must be handed in together with the answers.

The answers must be written with a pen; drawings and graphs can also be made with a pencil.

If an open question asks you to give an explanation or calculation, you will not receive any points if your answer does not include an actual explanation or calculation.

Do not give more answers (reasons, examples, etc.) than asked for in the question. If, for instance, you are asked to provide two reasons and you give more than two reasons, only the first two will be marked.

It is permitted to use BINAS, 5th edition or later, or BioData, 2nd edition.

The use of a normal calculator is permitted; graphic calculators are **not** permitted.

The maximum number of points for this exam is 69.
The marks are calculated as follows: $\text{mark} = \text{score}/69 \times 9 + 1$

The marking and the communication of the results will be handled entirely through CCVX . You will receive the result of your exam via CCVX.
For further proceedings and the progress of the marking procedure, see www.ccvx.nl

REMEMBER TO HAND IN THE QUESTIONS AS WELL!

Energy

Lactobacillus bulgaricus is a bacterial species that can be used for producing yoghurt from milk. Bacteria of this species break glucose down as shown in the diagram in Figure 1.

The bacterial species *Leuconostoc mesenteroides*, which is used for preparing kefir from milk, breaks down glucose as shown in the diagram in Figure 2 (see the following page). This dissimilation is entirely anaerobic in both species of bacterium.

You are given two test tubes, one containing *Lactobacillus bulgaricus* and the other containing *Leuconostoc mesenteroides*. You do not know which tube contains which bacterium. You are going to investigate this by growing bacteria of both species in Petri dishes on agar culture medium.

- What nutrient must all the culture media contain at the very least?
- What should you observe (as a minimum) to let you conclude which tube contains *Lactobacillus bulgaricus* and which tube contains *Leuconostoc mesenteroides*? (2 points)

Leuconostoc mesenteroides produces lactic acid (C3) and ethanol (C2) from glucose (C6) via ribose (C5).

- Explain why *Leuconostoc mesenteroides* can only make lactic acid if ethanol is produced at the same time. Use the diagram in Figure 2 in your explanation. No points will be given for stating the data from the text (numbers of carbon atoms) (2 points)
- Which of the diagrams in Figure 1 and Figure 2 represents a process that is a net producer of ATP? (2 points)
 - Neither of the diagrams
 - Only the diagram in Figure 1
 - Only the diagram in Figure 2
 - Both diagrams

Figure 1

Lactobacillus bulgaricus

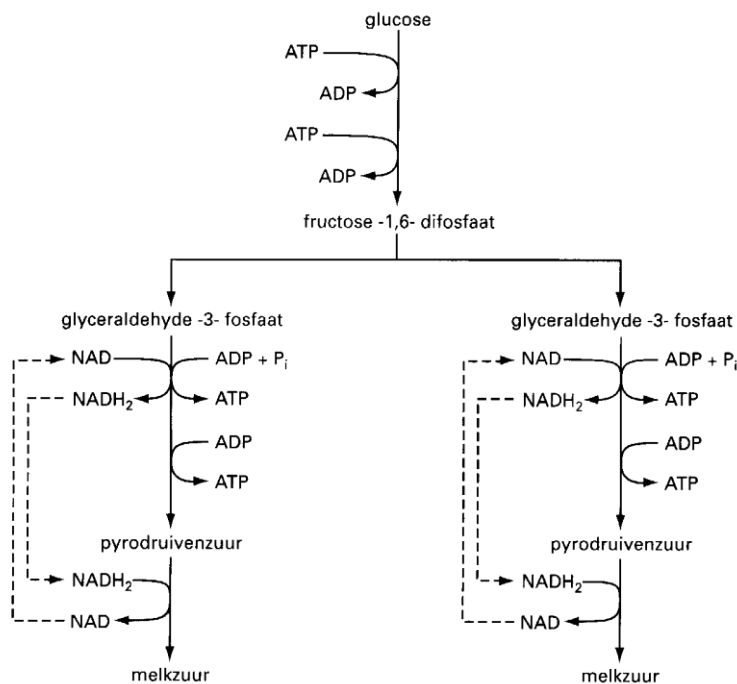

Text in Figure 1:

glucose	Glucose
fructose-1,6-difosfaat	Fructose-1,6-diphosphate
glyceraldehyde-3-fosfaat	Glyceraldehyde-3-phosphate
pyrodruivenzuur	Pyruvic acid
melkzuur	Lactic acid

Figure 2

Leuconostoc mesenteroides

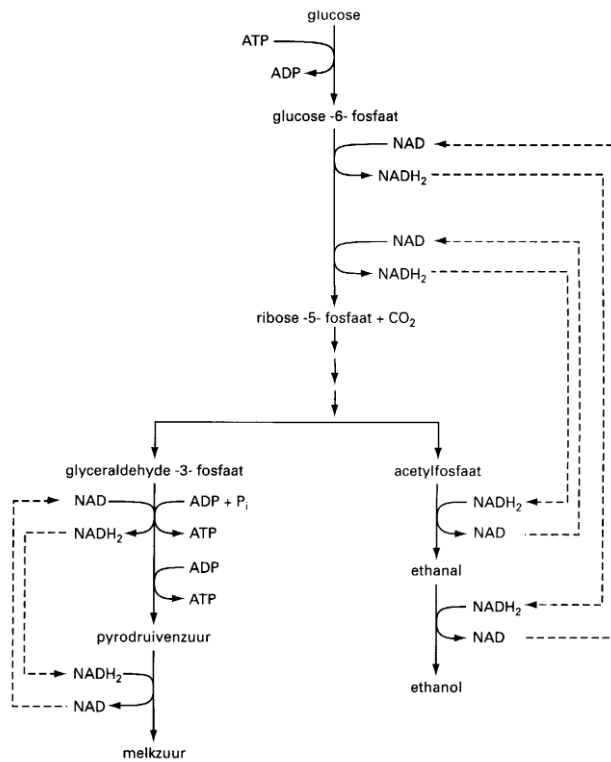

bewerkt naar: Th.D. Brock & M.T. Madigan, *Biology of microorganisms*, Englewood Cliffs; 1991, 772

Text in Figure 2:

glucose	Glucose
glucose-6-fosfaat	Glucose-6-phosphate
ribose-5-fosfaat	Ribose-5-phosphate
glyceraldehyde-3-fosfaat	Glyceraldehyde-3-phosphate
acetylfosfaat	Acetyl phosphate
ethanal	Ethanal
pyrodruivenzuur	Pyruvic acid
ethanol	Ethanol
melkzuur	Lactic acid
bewerkt naar TH.D. Brock & M.T. Madigan, <i>Biology of microorganisms</i> , Englewood Cliffs, 1991, 772	Adapted from T.D. Brock & M.T. Madigan, <i>Biology of microorganisms</i> , Englewood Cliffs, 1991, 772

Insulin

ATP is required for the secretion of insulin by β -cells in the islets of Langerhans.

4. State two places in the β -cells where ATP can be produced. (2 points)

Active insulin consists of two polypeptide chains with a total of only 51 amino acids.

5. What is the percentage of essential amino acids in it? (2 points)

- A 16%
- B 37%
- C 40%
- D 59%

Insulin also affects the metabolism of liver cells and muscle cells. Figure 3 uses numbered arrows to give a schematic representation of some of the conversions that take place in a liver cell.

afbeelding 3

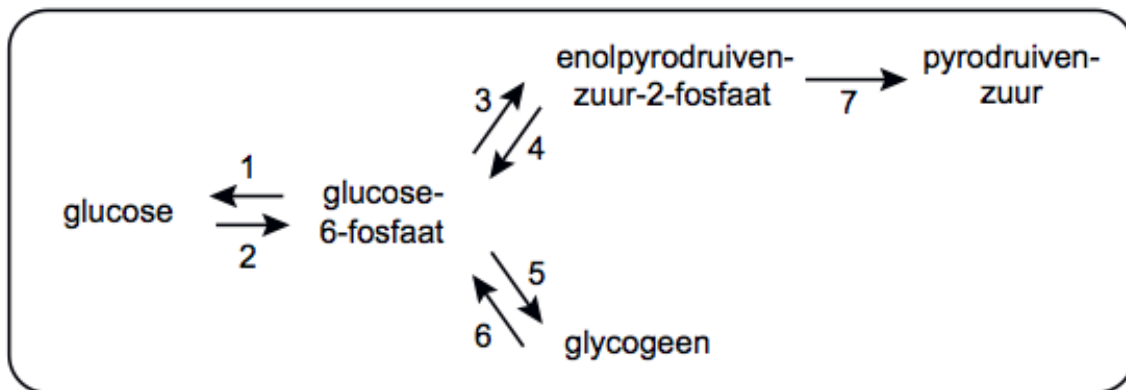

Text in Figure 3:

afbeelding 3	Figure 3
glucose	Glucose
glucose-6-fosfaat	Glucose-6-phosphate
enolpyrodruivenzuur-2-fosfaat	Enolpyruvic acid-2-phosphate
pyrodruivenzuur	Pyruvic acid
glycogeen	Glycogen

A woman suffers from diabetes because her pancreas secretes a decreasing amount of insulin.

6. Which of the numbered conversions will therefore take place to a less degree in her liver cells at first? (2 points)
- A 1 and 4
 - B 1 and 6
 - C only 2 and 5
 - D only 2, 3 and 7
 - E 2, 3, 5 and 7

Most of the conversions that are shown schematically for liver cells can also take place in muscle cells. However, conversion 1 is an exception because muscle cells do not contain the enzyme glucose-6-phosphatase.

7. - Explain why the presence of glucose-6-phosphatase is meaningful in liver cells.
- Explain why it is not useful for glucose-6-phosphatase to be present in muscle cells. (2 points)

Structure and function of the kidneys

Figure 4 uses four numbered arrows to indicate processes that take place in a nephron (functional kidney unit).

Reabsorption and ultrafiltration are two processes that take place in a nephron.

8. - Which arrow indicates reabsorption?
 - Which arrow indicates ultrafiltration? (2 points)

Figure 5 is a schematic representation of the structure of epithelial cells in the wall of the first convoluted tubule in a nephron.

Substances from the pre-urine are transported into the blood through the wall of the first convoluted tubule.

9. State two features of the epithelial cells drawn in Figure 5 that are associated with this transport of substances. (2 points)

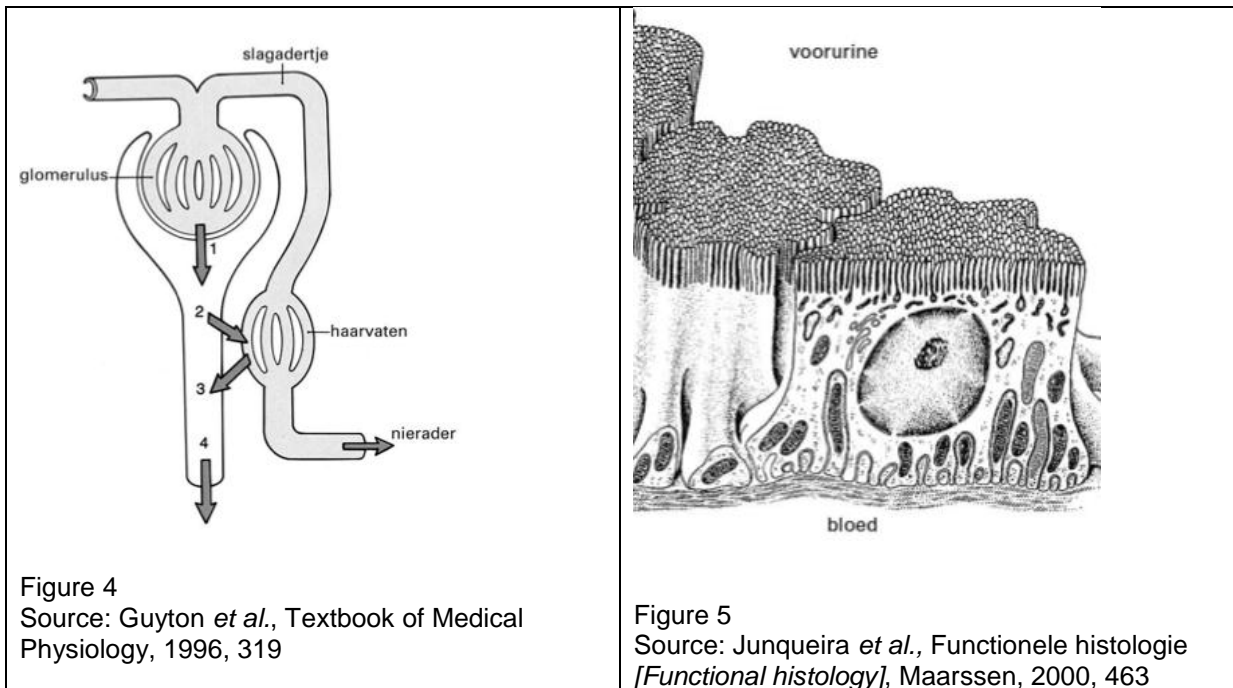

Figure 4
 Source: Guyton *et al.*, Textbook of Medical Physiology, 1996, 319

Figure 5
 Source: Junqueira *et al.*, Functionele histologie [Functional histology], Maarsse, 2000, 463

Text in Figures 4 and 5:

slagadertje	Small artery
glomerulus	Glomerulus
haarvaten	Capillaries
nierader	Renal vein
voorurine	Pre-urine / filtrate
bloed	Blood

Proteins, which can be found in the filtrate in low concentrations, are also absorbed from it by the epithelial cells of the tubule. Subsequently, these proteins are hydrolysed in the epithelial cells.

The hydrolysis products:

- Can be used by the epithelial cells themselves for producing components of the endoplasmic reticulum.
- Can be released into the blood.

10. Which of the statements is or are correct? (2 points)
- A Neither of the statements
 B Only statement 1
 C Only statement 2
 D Statements 1 and 2

Succession

An open area can occur in the vegetation of a rain forest. Succession can take place in this open area. Six characteristics of various plant species are:

- 1 Germination occurs in sunlight;
- 2 The seedlings cannot survive underneath foliage;
- 3 Large numbers of seeds are produced;
- 4 Seeds are produced in a specific season;
- 5 Seeds are dispersed by gravity over a small distance;
- 6 Seeds remain dormant in the soil as a kind of seed bank.

11. Which of these features are appropriate for the plant species that are the first to establish themselves in the open area? (2 points)
- A Only features 1, 3 and 4
 - B Only features 2, 4 and 5
 - C Only features 1, 2, 3 and 6
 - D Only features 3, 4, 5 and 6

The process of succession in an ecosystem is shown in Figure 6 using three different parameters. Line P shows the gross production, line Q the total biomass, and line R the total amount of dissimilation.

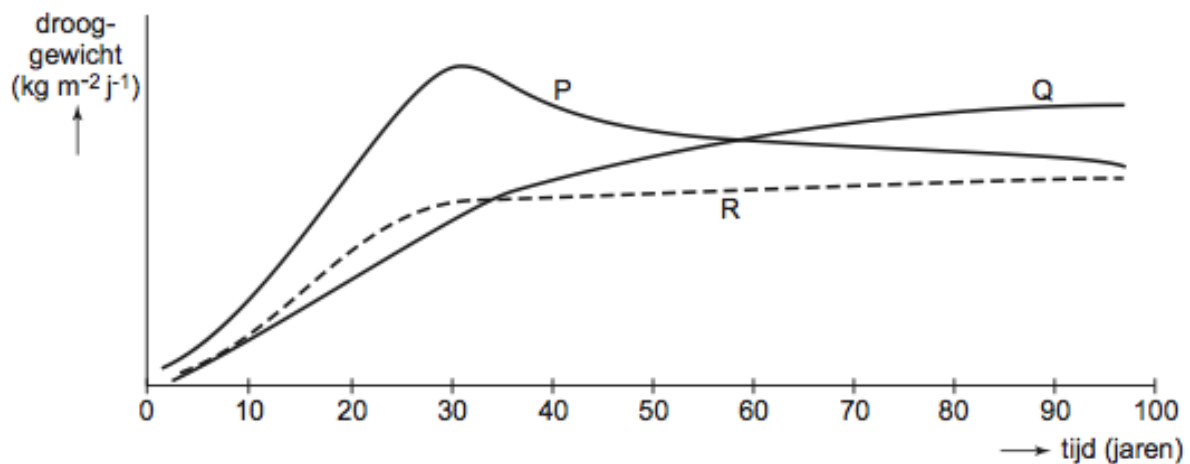

Figure 6.

Adapted from E.P. Odum, Fundamentals of ecology, Philadelphia, London, Toronto, 1971, 254

Text in Figure 6:

drooggewicht ($\text{kg} \cdot \text{m}^{-2} \cdot \text{j}^{-1}$)	Dry weight ($\text{kg} \cdot \text{m}^{-2} \cdot \text{yr}^{-1}$)
tijd (jaren)	Time (years)

The progress of the net production in this ecosystem can be determined based on the data in Figure 6.

The diagram from Figure 6 has been copied in the appendix for you to work with.

12. Indicate the net production progresses in time. Add a legend. (2 points)

Coding

Figure 7 is a schematic representation of the processes of transcription and translation in a cell.

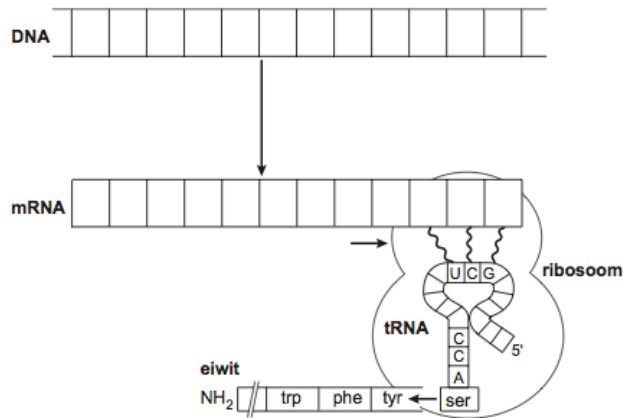

Adapted from Sibernagl and A. Despopoulos, *Sesam, Atlas van de Fysiologie [Atlas of Physiology]*, Baarn, 2001, 11 Figure 7

Text in Figure 7:

ribosoom	Ribosome
eiwit	Protein

The letters indicating the various nucleotides in the mRNA and DNA strands have been left out in this figure.

The diagram has been copied in the appendix for you to work with.

13. - In the diagram in the appendix, enter a set of twelve possible letters for the nucleotides in the mRNA and DNA strands shown. (3 points)
 - Indicate the 3' end and the 5' end of the mRNA and DNA strands.

In the coding for an enzyme, a mutant gene in the DNA may have replaced one nucleotide with another. Such a change usually leads to a non-functional enzyme in the mutant. Sometimes, such an error has no consequences for the functioning of the enzyme in question.

14. State two different possible reasons why a substituted nucleotide like this in the part of a gene coding for amino acids does not result in a non-functional enzyme. (2 points)

Malaria

Insects play important roles in many tropical diseases. In the case of malaria, mosquitoes of the genus *Anopheles* are involved. They transmit unicellular parasites of the genus *Plasmodium*. Of these parasites, *Plasmodium falciparum* is responsible for fatal cerebral malaria. It is an extremely dangerous disease, particularly for indigenous children aged between one and five and for tourists. The indigenous adult population have generally developed a certain resistance.

A female mosquito carrying malarial parasites can transmit them to a human when it bites them in order to suck blood, seemingly preferring humans who are feeling hot. The warm blood of humans causes the body temperature of the mosquito to rise.

15. Explain why the mosquito's preference for humans who are feeling hot is also functional when biting the blood vessel. (1 point)

A common feature of malaria is jaundice, caused by elevated breakdown of red blood cells. This creates a large amount of bilirubin, a breakdown product of haemoglobin.

16. Where is the concentration of bilirubin much higher than normal in jaundice? (2 points)
- A Only in the hepatic vein in the portal vein
 - B Only in the faeces
 - C Only in the urine
 - D In all blood vessels and in the urine

Certain proteins called pyrogens appear in white blood cells as a response to the release of the parasite's metabolic products. Pyrogens trigger a reaction in the hypothalamus, which makes the body temperature rise to 40 C or above. This is called a fever attack. The patient feels cold and starts shivering.

17. - Explain why you feel cold as the fever increases. (2 points)
- And explain why you then start shivering.

A nitrogen cycle

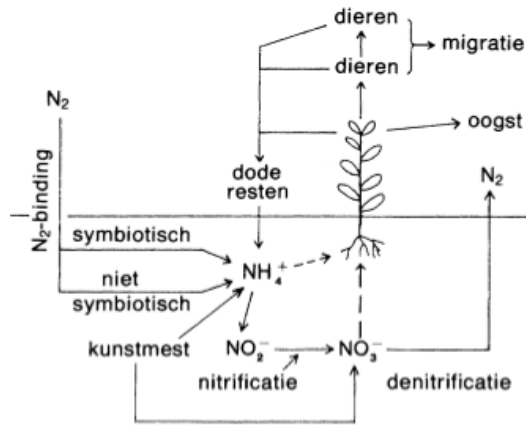

Source: A. Quispel and D. Stegwee (ed.), *Plantenfysiologie [Plant physiology]*, Utrecht/ Antwerp, 1983, 122 **Figure 8**

Text in Figure 8:

N_2-binding	N_2 binding
symbiotisch	Symbiotic
niet-symbiotisch	Non-symbiotic
dode resten	Dead remains
nitrificatie	Nitrification
dieren	Animals
migratie	Migration
oogst	Harvest
denitrificatie	Denitrification

NO_2^- , NO_3^- and NH_4^+ are three substances that are involved in the nitrogen cycle.

18. According to Figure 8, which of these substances is or are produced as a direct result of nitrogen fixation? (1 point)

Nitrogen gas (N_2) can enter the nitrogen cycle via a symbiotic or a non-symbiotic pathway, via NH_4^+ .

19. a. What is the difference between a symbiotic and a non-symbiotic pathway? (1 point)
 b. Give an example of each (2 points)

In vitro fertilisation

In *in vitro* fertilisation (IVF), ova are fertilised by sperm cells outside the body. An embryo develops and is then implanted into the womb, mostly at a multicellular stage, for example at the morula stage. Figure 9 shows three embryonic stages, including the morula.

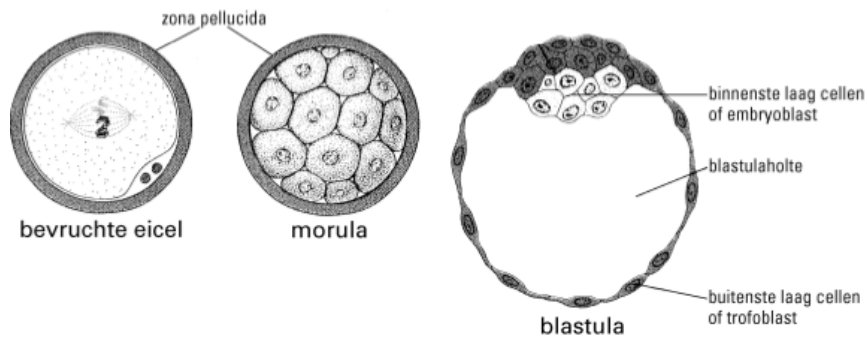

Source: T W Sadler, Langmans medische embryologie [*Langman's medical embryology*], Utrecht/Antwerp, 1988, 30-31

Figure 9

Text in Figure 9:

bevruchte eicel	Fertilised ovum
morula	Morula
zona pellucida	Pellucid zone
blastula	Blastula
binnenste laag cellen of embryoblast	Inner layer of cells or embryoblast
buitenste laag cellen of trofoblast	Outer layer of cells or trophoblast

The preference for implanting embryos at the morula stage is based on the idea that other stages are less suitable for implantation.

20. - State a reason why a fertilised ovum is thought to be less suitable for implantation in the womb.
- State another reason why a blastula is thought to be less suitable for implantation in the womb. (2 points)

Bacteria and viruses

In an experiment, bacteria of the same species are placed in two solutions (1 and 2) with different osmotic values. The experiment is shown schematically in Figure 10. It indicates what happens to a bacterium in each of the solutions. The solutions contain the same amounts of lysozymes. Lysozymes are enzymes that affect the cell wall of a bacterium.

The material contained inside the bacterium is released in both solutions. The cell membrane bursts in solution 1, but not in solution 2. The bacterial content is not isotonic with one of the two solutions.

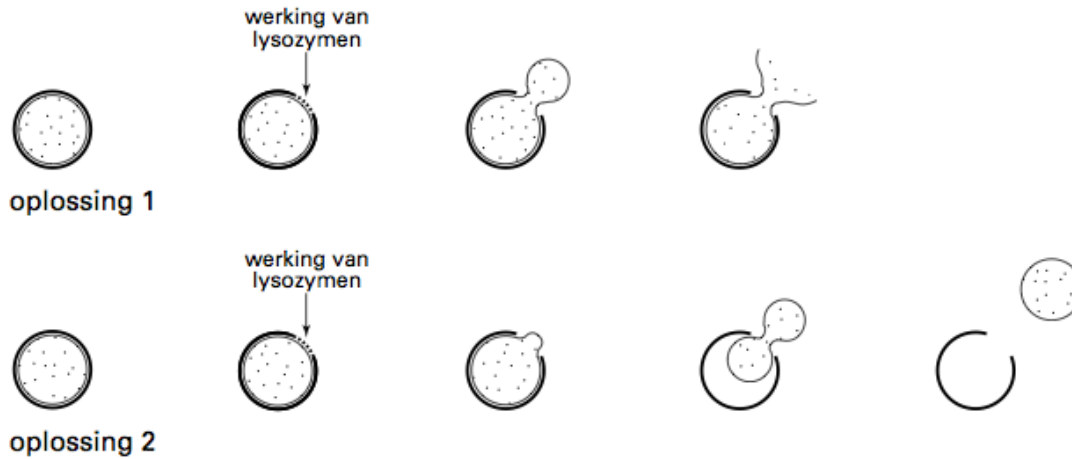

Figure 10. Adapted from T.D. Brock & M.T. Madigan, Biology of microorganisms, Englewood Cliffs, 1991, 60

Text in Figure 10:

oplossing 1	Solution 1
werking van lysozymen	Action of lysozymes
oplossing 2	Solution 2
werking van lysozymen	Action of lysozymes

21. Why does the cell membrane burst in solution 1, but not in solution 2? (2 points)
- A Because the osmotic value of solution 1 is greater than that of solution 2, and greater than the osmotic value in the bacterium.
 - B Because the osmotic value of solution 1 is greater than that of solution 2, but lower than the osmotic value in the bacterium.
 - C Because the osmotic value of solution 1 is lower than that of solution 2, but greater than the osmotic value in the bacterium.
 - D Because the osmotic value of solution 1 is lower than that of solution 2, and lower than the osmotic value in the bacterium.

Cats

The colour and the patterning of cats' fur are determined by at least ten different genes. The alleles X^D for ginger and X^d for black coat colouring are X-chromosomal. In a heterozygous female ($X^D X^d$), the X^D chromosome is turned off in some cell lines during embryonic development, whereas in other cell lines the X^d chromosome is turned off. This gives the cat a pattern of ginger and black patches. The exact pattern depends on the stage of embryonic development at which an X chromosome has been turned off.

An ginger male cat mates with a homozygous black female. They have a litter of four kittens. These kittens are all female. Their colouring is as follows:

Kitten 1 is ginger.

Kitten 2 is black.

Kitten 3 is about two thirds ginger; the orange colour is broken up by 5 black patches.

Kitten 4 is about two thirds black; the black colour broken up by 5 orange patches.

22. In which of kittens 1, 2, 3 and 4 will the X^D chromosome in the cell line that determines the coat colour have been turned off first during embryonic development? (2 points)
- A Kitten 1
 - B Kitten 2
 - C Kitten 3
 - D Kitten 4

The coat colour is also affected by a non-X-chromosomal allele pair: if allele S is present, the coat will have white patches; a homozygous recessive cat (ss) will have no white patches. Calico (tricoloured) cats have orange, black and white patches.

Female and male cats with the following genotypes live in the same neighbourhood:

Minet with genotype $X^D X^D$ ss;

Gus with genotype $X^d X^d$ Ss;

Tommy with genotype $X^D Y$ ss;

Max with genotype $X^d Y$ SS;

Fluffy with genotype $X^d Y$ Ss;

Rasta with genotype $X^d Y$ Ss.

Any of these male and female cats could mate with each other and they are all equally fertile.

23. - Which female cat has to mate with which male cat to produce a litter with as many calico cats as possible?
- And how big is the chance that a female cat in such a litter will be a calico cat? (2 points)
- A Minet and Rasta, 100%
 - B Minet and Max, 100%
 - C Gus and Tommy, 25%
 - D Gus and Fluffy, 25%

Fetal circulation

The table gives the blood flow rate in various parts of the fetal circulation.

	Flow rate in mL min ⁻¹ kg ⁻¹ bodyweight
Superior vena cava	78
Inferior vena cava	182
Right ventricle	169
Pulmonary veins (together)	13

24. How many millilitres of blood flow each minute from the left ventricle directly into the aorta of an unborn baby weighing 3 kilograms? (2 points)
- A 91
 - B 104
 - C 156
 - D 273
 - E 312

The oxygen saturation of the blood depends among other things on the oxygen pressure. The oxygen saturation curve of the haemoglobin of a pregnant woman is different from the curve of the foetal Hb of her unborn child. There is hardly any difference at lower pO₂ values (below 2 kPa/15 mmHg) or higher pO₂ values (above 10 kPa/75 mm Hg), but there is a difference in the intermediate range.

25. - In this range (pO₂ between 2 and 10 kPa), is the O₂ saturation of the blood of the expectant mother higher or lower than the O₂ saturation of her unborn child? (2 points)
- Explain the significance of this.

After the baby is born, its blood circulation adapts to the new situation. The resistance in the pulmonary vessels decreases and therefore the resistance in the right side of the heart. The muscles in the left side of the heart become stronger. If the foramen ovale (oval window) does not close completely, blood may flow from the left atrium into the right atrium. The abnormalities can then include:

1. Higher blood pressure than normal in the pulmonary artery;
2. Lower pO₂ than normal in the pulmonary artery.

26. Which of these abnormalities can be caused by incomplete closure of the oval window? (2 points)
- A Neither
 - B Only 1
 - C Only 2
 - D Both 1 and 2

A stomach ulcer

Many people who have stomach ulcers know it all too well: once the *Helicobacter pylori* bacterium has become embedded in the stomach's mucous membrane, it is not easy to get rid of it.

If *H. pylori* has established itself in the gastric mucosa, it means that the non-specific defences in the gastrointestinal tract have not worked sufficiently.

27. State two ways in which the non-specific defence mechanism can prevent stomach infections caused by bacteria. (2 points)

The *H. pylori* bacterium can be transmitted between humans.

28. Describe a route by which *H. pylori* can be transmitted from human to human. (1 point)

Muscle reflexes

The figure shows a diagram of a circuit for a number of neurons that are connected to the flexor and extensor muscles of the lower leg. Some of these neurons have been numbered (next to their cell bodies). The tendon sensors and muscle spindles respond to stretching.

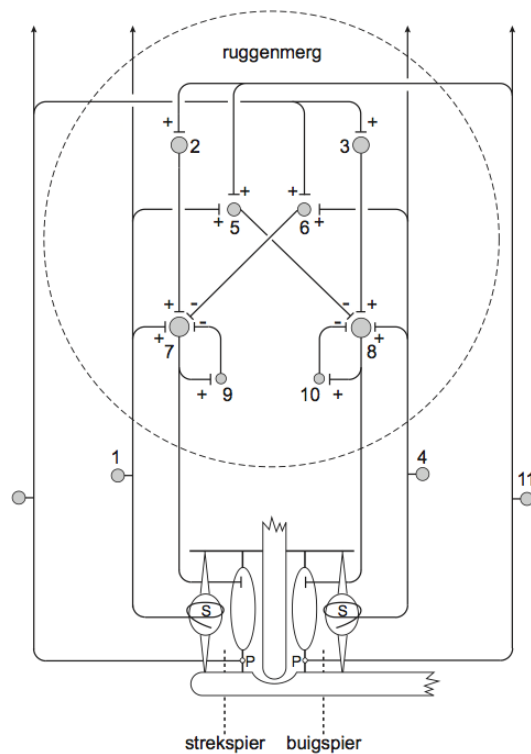

Figure 11

Text in Figure 11:

ruggenmerg	Spinal cord
strekspier	Extensor muscle
buigspier	Flexor muscle
legenda	Legend
spierspoel	Muscle spindle
peesensor	Tendon sensor
synaps	Synapse

The patellar tendon is tapped just below the knee to trigger the muscle reflex. As a response, the lower leg is briefly extended.

29. Which of the numbered neurons in the diagram in the figure above release a transmitter substance during this reflex? (2 points)
- A Only 1 and 5
 - B Only 4 and 6
 - C Only 1, 5 and 8
 - D Only 1, 5, 7 and 9
 - E Only 4, 6, 8 and 10
 - F 1, 2, 5, 7 and 9

The following figure shows a diagram of the cell body of neuron 7 from Figure 11 along with a number of dendrites of other neurons. At a certain moment, a signal is measured using a potentiometer, as shown in the drawing.



Figure 12

30. Stimulation of which neuron or neurons from Figure 11 could have caused this signal? (2 points)
- A Only neuron 6
 - B Only neuron 7
 - C Only neurons 6 and 9
 - D Only neurons 2 and 7
 - E Neurons 2, 6, 7 and 9

When a muscle fibre contracts, actin and myosin filaments slide past each other. This changes the position of the H-zone, the A-band and the I-band (see the figure below) in a sarcomere.

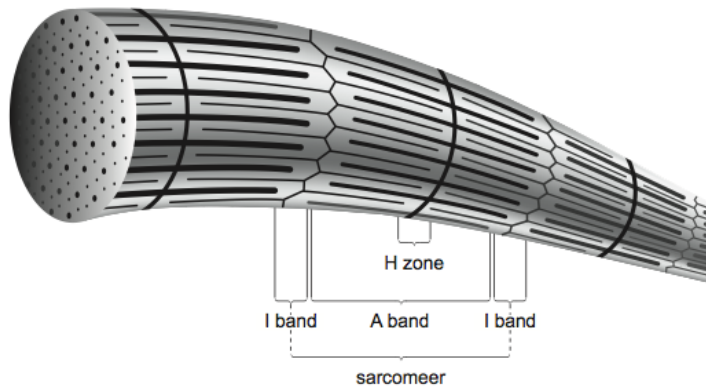

Figure 13





Text in Figure 13:

H zone	H-zone
I band	I-band
A band	A-band
sarcomeer	Sarcomere

31. What changes take place in the width of these bands and zones during contraction of the muscle fibre? (2 points)
- A H, A and I will all become narrower
 - B H and A become narrower, I remains the same
 - C H becomes narrower, A remains the same, and I becomes narrower
 - D H remains the same, A and I become narrower
 - E H becomes narrower, A and I remain the same

Dinosaurs

Much has been learned about the structure of the skeletons of dinosaurs by studying fossil remains of these animals. Figure 13 gives an overview of a number of characteristic features of the skeletons of five different genera. Plus or minus signs show whether the feature is present or not.

	Allosaurus 	Pachycephalosaur 	Parasaurolophus 	Stegosaurus 	Triceratops 
gat in kom heupgewricht	+	+	+	+	+
uitsteeksel heupbeen	-	+	+	+	+
afwijkend tandglazuur	-	+	+	-	+
rand aan schedelbasis	-	+	-	-	+

bron: N.A. Campbell, *Biology, Menlo Park California, 1999, 484*

Figure 14

Text in Figure 14:

Allosaurus	Allosaurus
Pachycephalosaur	Pachycephalosaur
Parasaurolophus	Parasaurolophus
Stegosaurus	Stegosaurus
Triceratops	Triceratops
Stegosaurus	Stegosaurus
gat in kom heupgewricht	Hole in the socket of the hip joint
uitsteeksel heupbeen	Protrusion on the pelvis
afwijkend tandglazuur	Abnormal tooth enamel
rand aan schedelbasis	Edge around the base of the skull
bron: N.A. Campbell, <i>Biology, Menlo Park, California, 199, 184</i>	Source: N.A. Campbell, <i>Biology, Menlo Park, California, 199, 184</i>

A 'family tree' can be set up as shown in Figure 14, based on the data in Figure 13. Each branch in this diagram has an ancestor with a newly developed, characteristic skeletal feature. This property can then also be found in all its descendants.

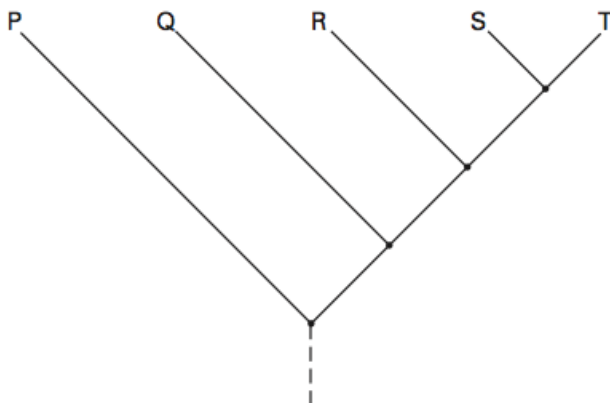

Figure 15

The names of the five genera from Figure 13 are not filled in the diagram in Figure 15. They are indicated instead by the letters P, Q, R, S and T.

32. Write the letters P through to T as a column on your answer sheet. Write down the names of the corresponding genus after each of the letters. There are two genera whose names can be transposed. (2 points)

Looking at objects

A person P is looking at an object that is 8 metres away. After that he looks at an object that is only 1 metre from his eyes.

33. Will this change result in impulses towards the ciliary body in his eye? If so, will this increase or decrease the tension in the ciliary processes? (2 points)
- A No.
 - B Yes, it will decrease the tension in the ciliary processes.
 - C Yes, it will increase the tension in the ciliary processes.

While person P is looking at the object that is at a distance of 1 metre from his eyes, a change in his surroundings occurs as a result of which the iris sphincter muscles contract.

34. What change might that have been? (1 point)

Person Q can only see objects sharply at a distance of about 8 metres. He cannot see objects sharply that are closer or further away.

For his work, Q is given a pair of glasses with special lenses. They are ground in such a way that the upper halves of the spectacle glasses act as convex lenses and the lower halves as concave lenses. Person Q is wearing the glasses. After looking at an object at a distance of 1 metre, which can be seen sharply, he then looks at an object that is 20 metres away. Both objects are at the same height.

35. What movement does he have to make so he can see the object at a distance of 20 metres sharply? (2 points)
- A He has to tilt his head back.
 - B He has to tilt his head forward.
 - C He has to lower his eyelids.
 - D He has to look with half-closed eyes.

End _____

Sub question 12

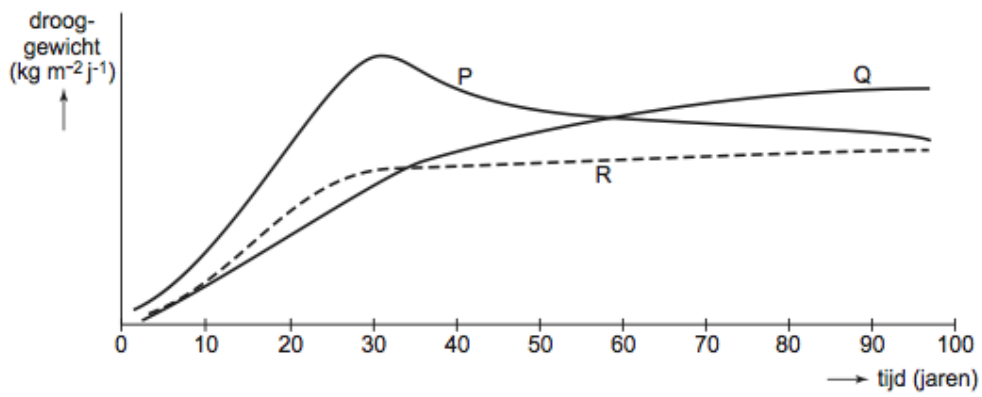

Text in the figure:

drooggewicht ($\text{kg.m}^{-2}.\text{j}^{-1}$)	Dry weight ($\text{kg.m}^{-2}.\text{yr}^{-1}$)
tijd (jaren)	Time (years)

Sub question 13

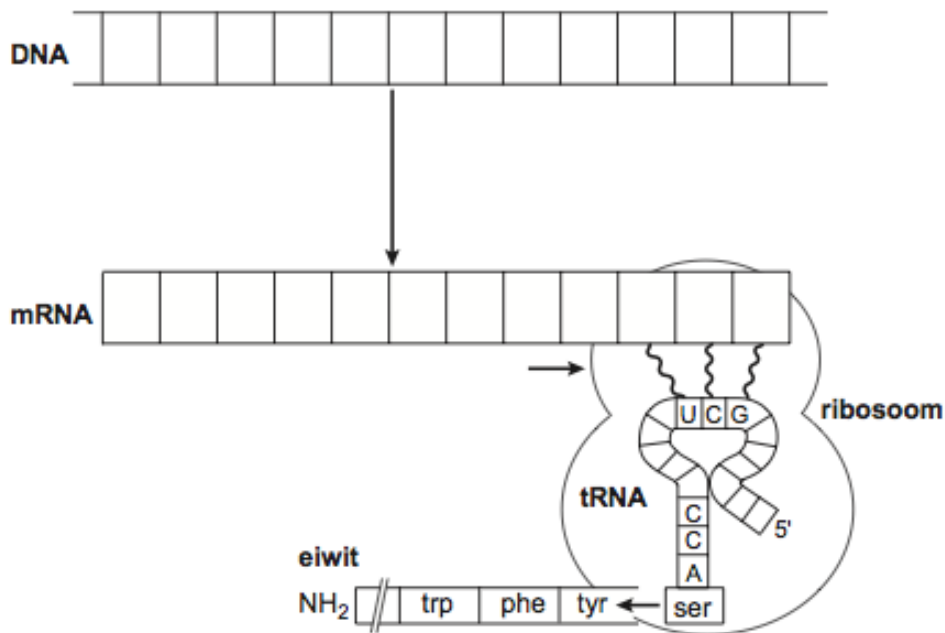

Text in the figure:

ribosoom	Ribosome
eiwit	Protein

Hand in this sheet together with the answer sheets and the exercises.